

**Estrazione parziale**

Corsa di estrazione circa il 70 - 80 % della lunghezza del binario

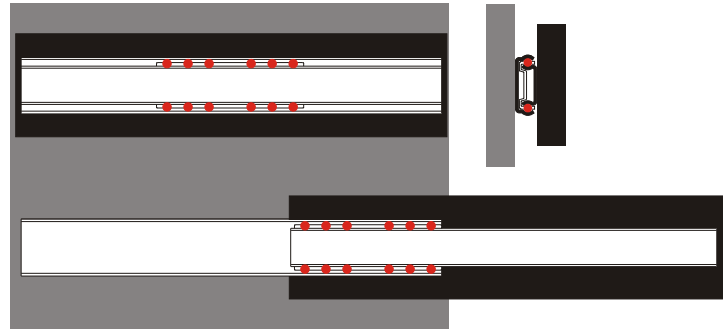

**Estrazione totale "Classic"**

Corsa di estrazione  $\geq 100\%$  della lunghezza del binario

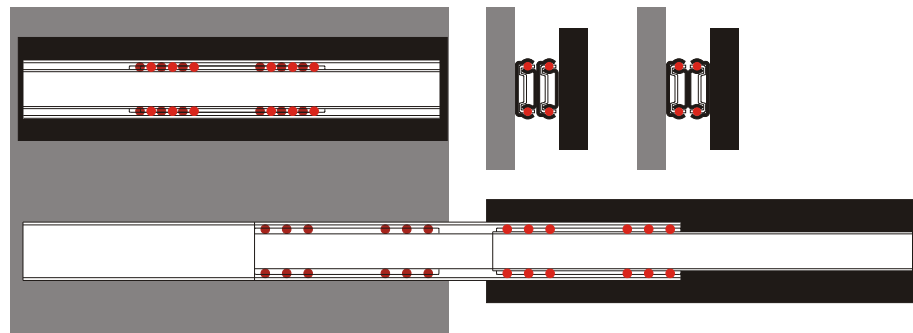

**Estrazione totale "Compact"**

Corsa di estrazione  $\geq 100\%$  della lunghezza del binario

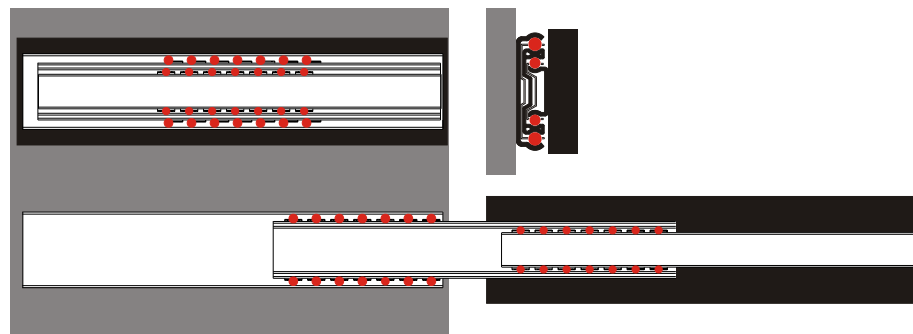

**Guida lineare**

Corsa di traslazione all'interno della lunghezza del binario

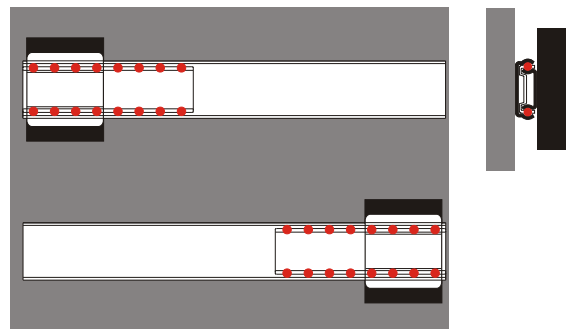

**Profili di base - Estrazioni parziali**

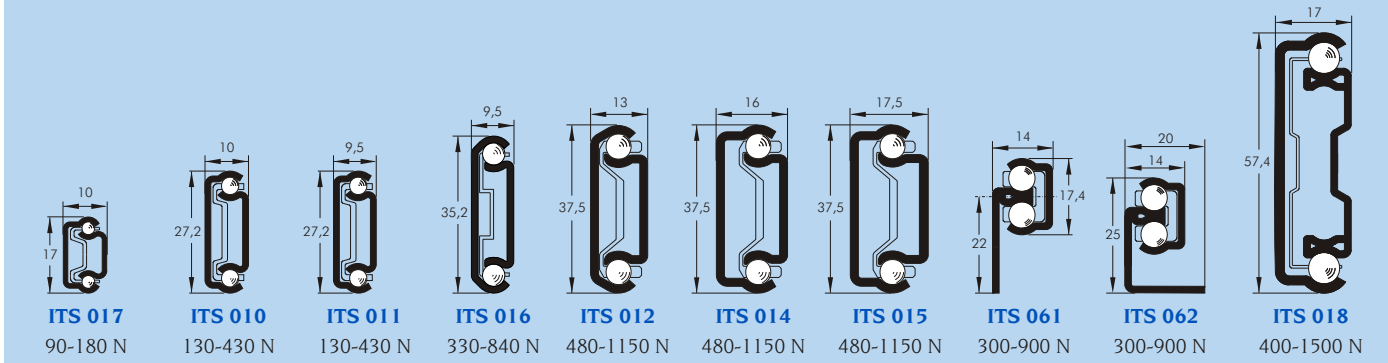

**Profili di base - Estrazioni totali**

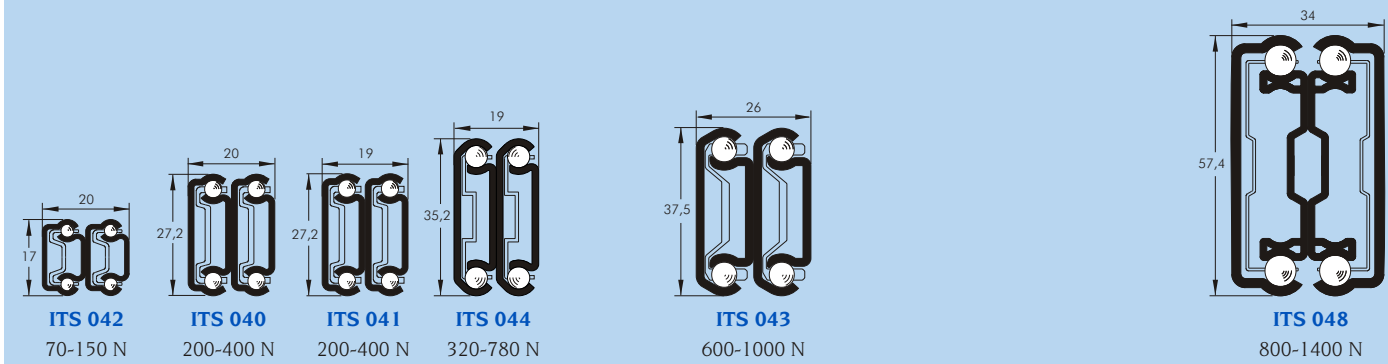

**Profili di base - Estrazioni parziali**

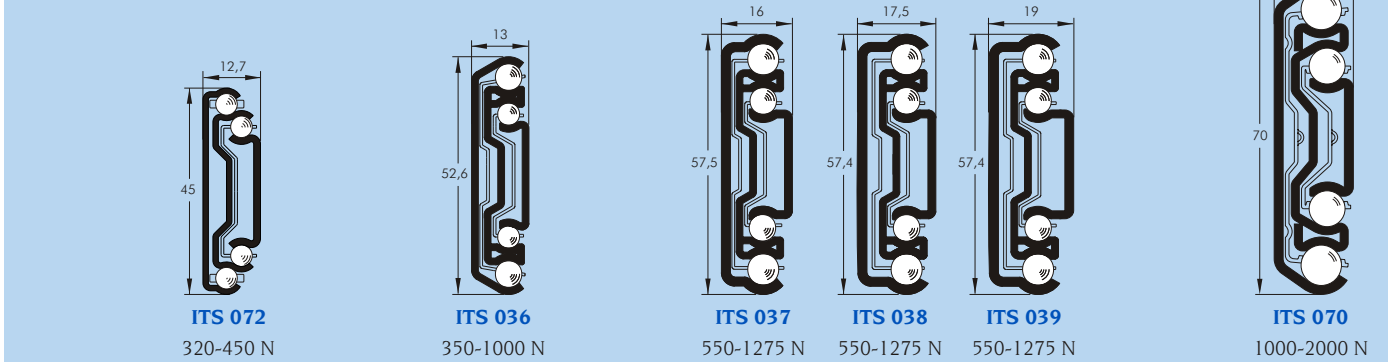

**Profili di base - Guide lineari**

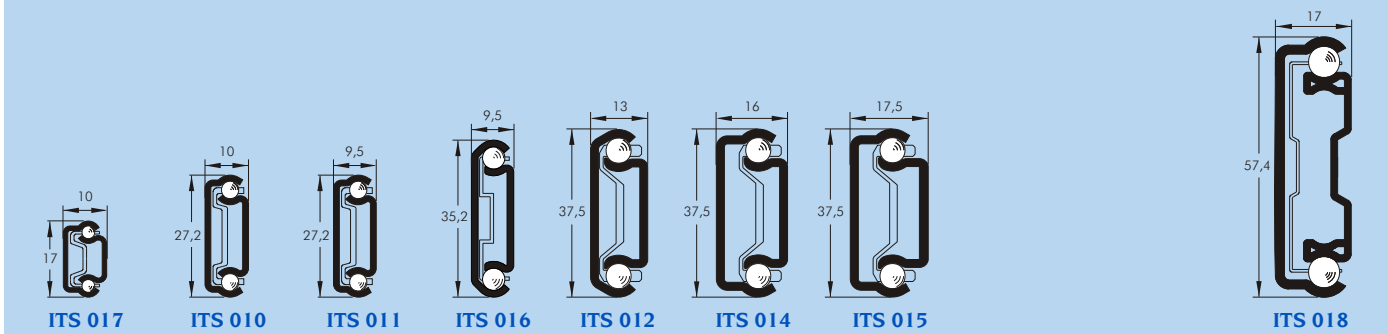

**Acciaio inox**

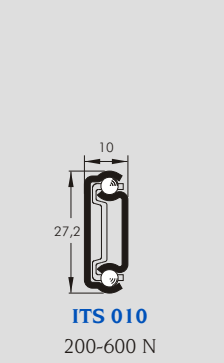

**Disegni speciali**

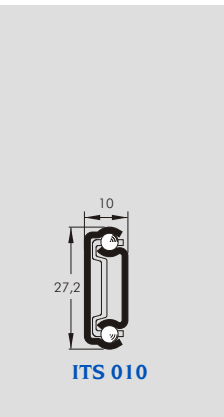
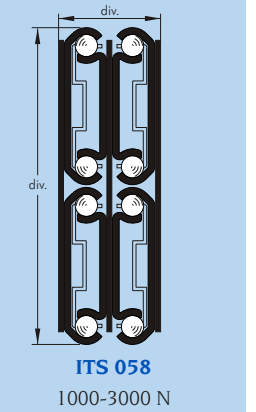
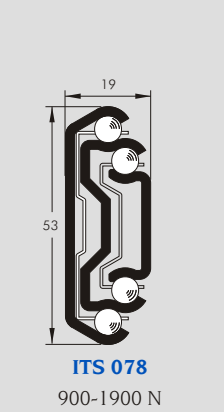
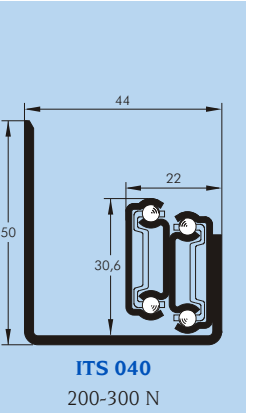
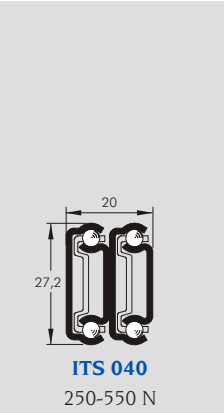
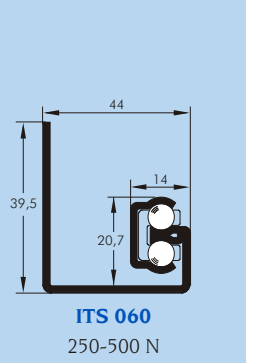

**!**  
Le portate indicate in [N] sono valori indicativi per 1 coppia di guide a sfere montate verticalmente per 100.000 o 10.000 cicli.  
Le misure dei profili sono indicate in [mm].