

Full extension pantry slide

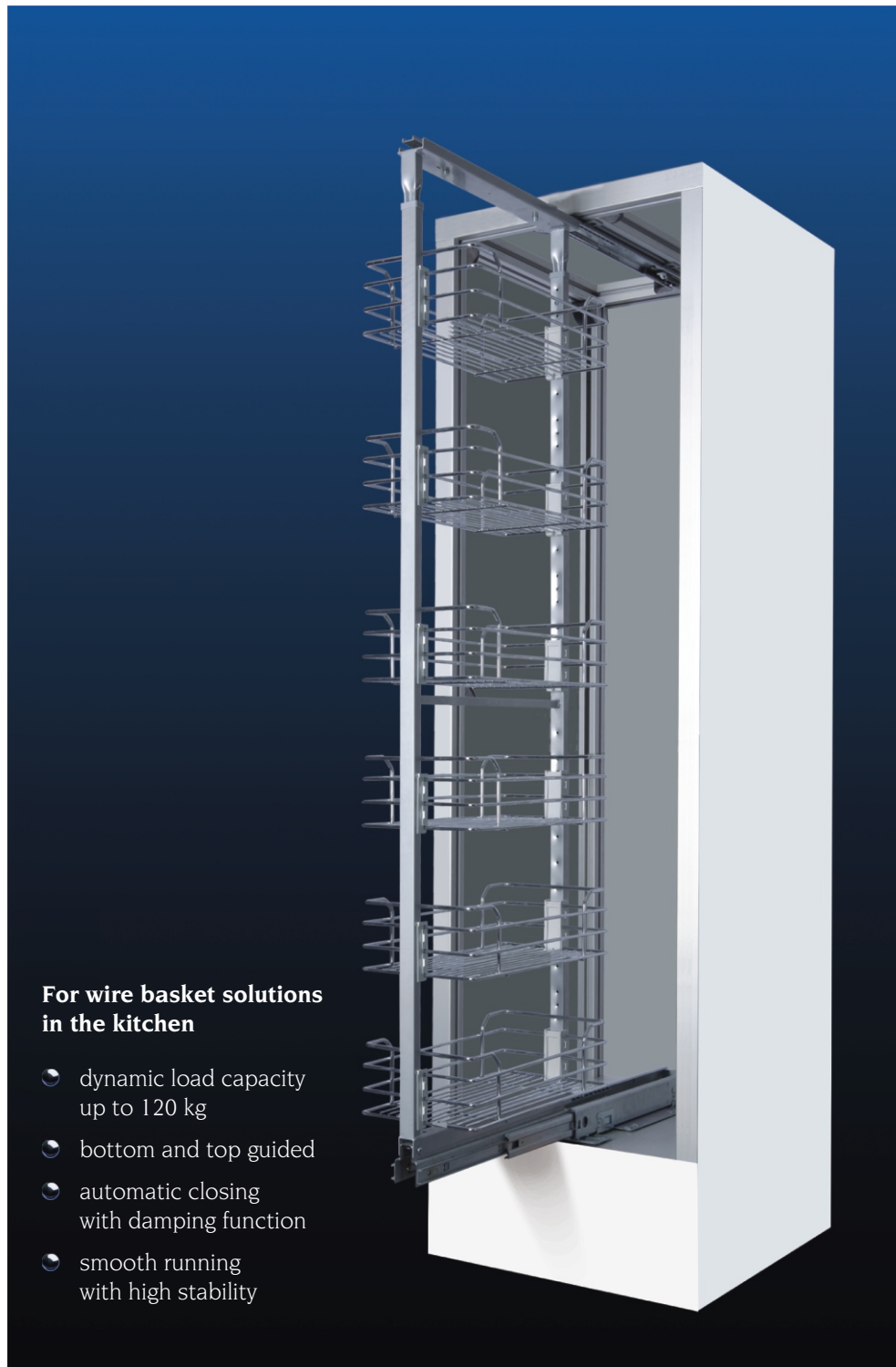

For wire basket solutions in the kitchen

- dynamic load capacity
up to 120 kg
- bottom and top guided
- automatic closing
with damping function
- smooth running
with high stability

Full extension pantry slide

- For wire basket solutions in the kitchen
- Load capacity up to 120 kg
- 50 mm self-closing device with damper in both bottom and top slide unit
- Packed per set - ready to install
- Material of slide rails: zinc plated steel
- Material of ball retainers: pre-zincd steel
- Material of balls: hardened precision steel

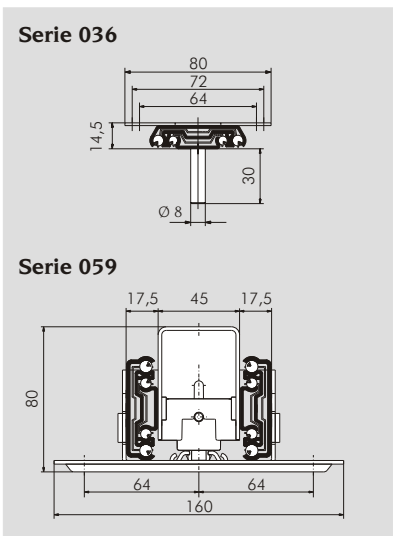
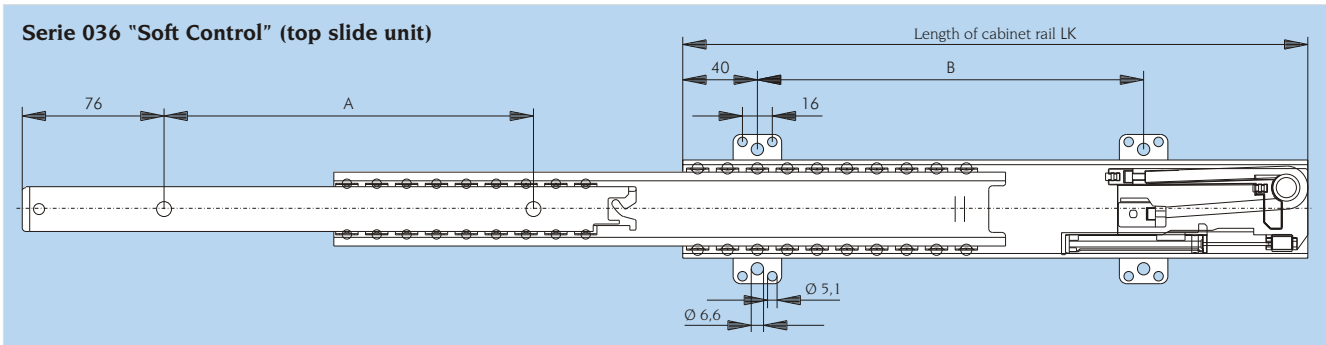
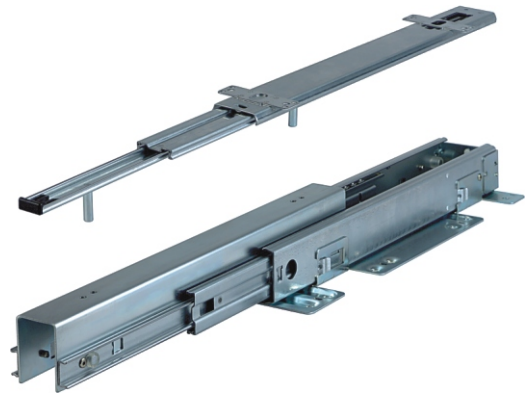

Interior depth [mm]	LK [mm]	Slide travel [mm]	Top slide unit		Bottom slide unit		Set No.
			A [mm]	B [mm]	C [mm]	D [mm]	
330	325	310
455	450	435
485	480	465	320	352	336	140	059.10350
505	500	485
605	600	585

Subject to technical amendment - other lengths and hole pattern on request

